

WIENER

•GIV•

DESIGN

ADDENDUM²⁰²⁴



a journal of Gebrüder Thonet Vienna GmbH

Interno Marche

slow living



WIENER
•GIV•
DESIGN



GTV furnishes the prestigious spaces of Interno Marche

Gebrüder Thonet Vienna GmbH (GTV) furnishes the prestigious spaces of Interno Marche, the first Design Experience Hotel that tells the story of 60 years of design history. In the centre of the Marche, in a beautiful setting of small villages and soft hills, the dream hotel of Franco Moschini, patron and current president of Gebrüder Thonet Vienna, is born. Michele De Lucchi, GamFratesi, Vico Magistretti, Front and Nendo are among the famous names of architects and designers who have collaborated with GTV and to whom some of the rooms of the design hotel are inspired, enriched by their most iconic works. Protagonists of the refined spaces such as lobby, lounge bar and patio, some of the most famous contemporary creations of the brand, such as the Loie lounge by Chiara Andreatti and the Targa sofa by GamFratesi together with the Arch Coffee Table by Front. The Ample chair and bistro tables, designed by Nichetto Studio, recreates the unmistakable refined atmosphere of the historic Viennese bistro, furnishing the restaurant and the patio with the new outdoor version of the Ample family.

- **With this prestigious supply, Gebrüder Thonet Vienna reconfirms itself as the ideal partner for sophisticated contract projects around the world thanks to the refined elegance of the lines and the high design quality of its creations.**





location:

**Interno Marche Design Experience Hotel,
Tolentino (MC)**

latitude:

43° 12' 36.851" N

longitude:

13° 17' 16.325" E



Stories, visions, inspirations.

Interno Marche is much more than a hotel, it is a dream that becomes a project and finally a reality. It encloses a story of the past and the value of a place, of work and the people who built and lived it.

The rebirth of Villa Gabrielli



Villa Gabrielli, a late Liberty jewel, symbol of the development of the city of Tolentino in the last century. In 1922, the building was initially a factory and the residence of entrepreneur Nazareno Gabrielli, creator of the famous Italian fashion brand. After him, it became the first production site of the new Poltrona Frau and the residence of Franco Moschini. The heritage of the place is preserved in the Interno Marche project, which, has rethought and recreated with care these spaces these spaces of work, family, lived life and has thus returned them to the city.





lobby

The 'Frame' is the heart of Interno Marche, an exhibition volume for installations and works of art, whose contents are curated by the Design Terrae Foundation.















the corridors

They host panels, works and installations that tell stories and visions linked to Franco Moschini's love for the "beautiful good and well made".







bistrot

Located in the old premises where leather was processed, it represents Franco Moschini's bond with the land of Marche. L'Opificio is designed to welcome and serve guests "in the manner of Franco Moschini". A culinary proposal that combines tradition, internationality and care, a love for history that is perceived both in the dishes and in the furnishings, in a cozy and authentic restaurant.

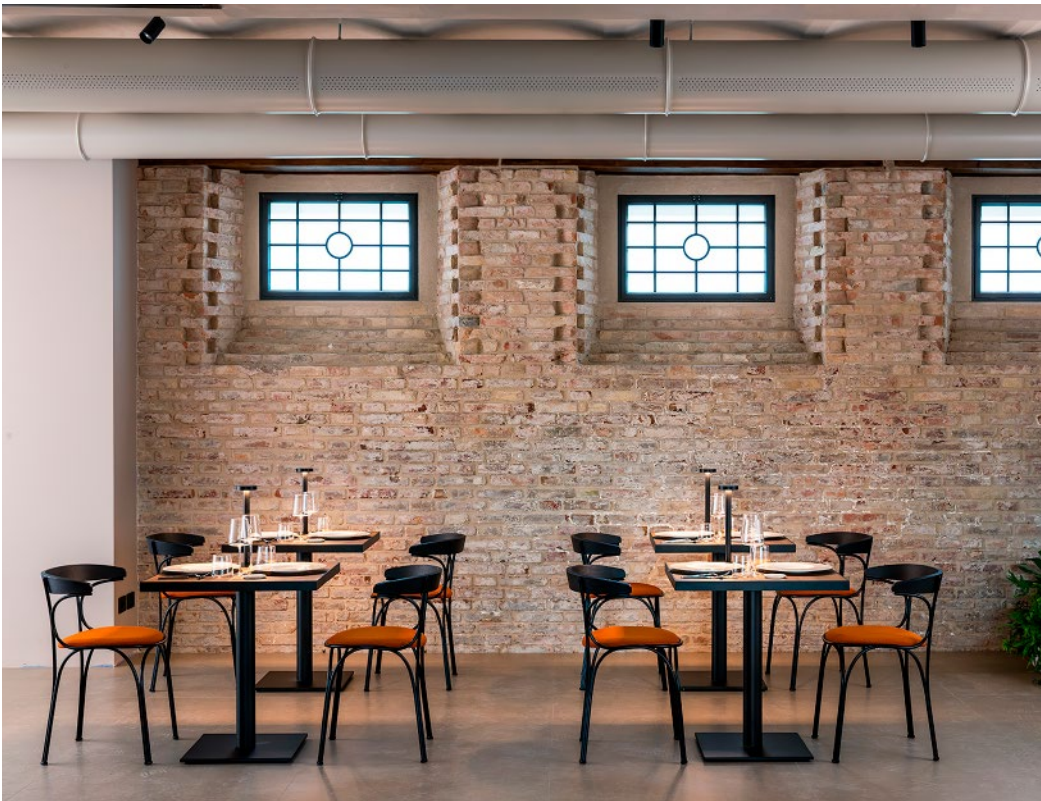







30

Iconic guest rooms.













La storia del design italiano ci stimola
con pensieri e linguaggi molto forti.
La storia del design scandinavo ci insegna
ad apprezzare il progetto non tanto in termini
di singolo prodotto quanto di processo.















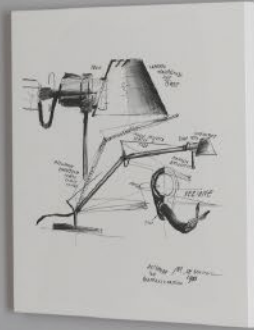

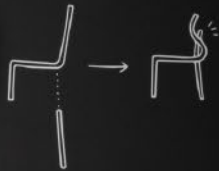





‘Beautiful, good and well made’.

A challenging project for the territory.







Franco Moschini

The local and international value of his history.

Franco Moschini, entrepreneur and patron, has made Made in Italy famous throughout the world, proudly believing in Italian taste and craftsmanship.

He is the founder of the new Poltrona Frau, owner of Gebrüder Thonet Vienna and lover of his homeland, Le Marche.



INTERNOMARCHE
DESIGN EXPERIENCE HOTEL

Viale Cesare Battisti, 15 - 62029 Tolentino MC
www.internomarche.it

 @internomarche

INDEX

History 3
The technique of wood bending 4
Products 7



Ample Outdoor Collection

40



Mon-Île Collection

8



You

30

Prospekt-Fabrik.

PARIS, 15 Boulevard Poissonnière.
Grande Manufacture, Paris 1870
LONDON, 124 High Holborn.
Grande Manufacture, London 1870

Kaiserl. Königl. landespriv. Fabriken
massiv-gebogener Holzarbeiten
VON
GEBRÜDER THONET.
Fabriks-Niederlage in **WIEN** untere Donau-Strasse 1
nächst der Ferdinandsbrücke.

BERLIN, W. Leipziger-Strasse 28
Salzerei-Materialie, Cassel 1870
Westausstellung in Wien 1873.
BRUNN, Ferdinands-Platz 7.
HAMBURG, Hermann-Strasse 27.
AMSTERDAM, Kalverstraat E. 66.
NEW-YORK, Broadway 808.

Schöne Aussicht, Hamburg 1874
Grande Exposition, Vienne 1876

Grande gold. Medaille, Vienne 1876
A. Mayer & Co. Export-Commission

Kinder-Möbel, Meubles d'enfants, Child's Furniture.

No. 1000 - 1009

No. 1010 - 1019

No. 1020 - 1029

No. 1030 - 1039

No. 1040 - 1049

No. 1050 - 1059

No. 1060 - 1069

No. 1070 - 1079

No. 1080 - 1089

No. 1090 - 1099

No. 1100 - 1109

No. 1110 - 1119

No. 1120 - 1129

No. 1130 - 1139

No. 1140 - 1149

No. 1150 - 1159

No. 1160 - 1169

No. 1170 - 1179

No. 1180 - 1189

No. 1190 - 1199

No. 1200 - 1209

No. 1210 - 1219

No. 1220 - 1229

No. 1230 - 1239

No. 1240 - 1249

No. 1250 - 1259

No. 1260 - 1269

No. 1270 - 1279

No. 1280 - 1289

No. 1290 - 1299

No. 1300 - 1309

No. 1310 - 1319

No. 1320 - 1329

No. 1330 - 1339

No. 1340 - 1349

No. 1350 - 1359

No. 1360 - 1369

No. 1370 - 1379

No. 1380 - 1389

No. 1390 - 1399

No. 1400 - 1409

No. 1410 - 1419

No. 1420 - 1429

No. 1430 - 1439

No. 1440 - 1449

No. 1450 - 1459

No. 1460 - 1469

No. 1470 - 1479

No. 1480 - 1489

No. 1490 - 1499

No. 1500 - 1509

No. 1510 - 1519

No. 1520 - 1529

No. 1530 - 1539

No. 1540 - 1549

No. 1550 - 1559

No. 1560 - 1569

No. 1570 - 1579

No. 1580 - 1589

No. 1590 - 1599

No. 1600 - 1609

No. 1610 - 1619

No. 1620 - 1629

No. 1630 - 1639

No. 1640 - 1649

No. 1650 - 1659

No. 1660 - 1669

No. 1670 - 1679

No. 1680 - 1689

No. 1690 - 1699

No. 1700 - 1709

No. 1710 - 1719

No. 1720 - 1729

No. 1730 - 1739

No. 1740 - 1749

No. 1750 - 1759

No. 1760 - 1769

No. 1770 - 1779

No. 1780 - 1789

No. 1790 - 1799

No. 1800 - 1809

No. 1810 - 1819

No. 1820 - 1829

No. 1830 - 1839

No. 1840 - 1849

No. 1850 - 1859

No. 1860 - 1869

No. 1870 - 1879

No. 1880 - 1889

No. 1890 - 1899

No. 1900 - 1909

No. 1910 - 1919

No. 1920 - 1929

No. 1930 - 1939

No. 1940 - 1949

No. 1950 - 1959

No. 1960 - 1969

No. 1970 - 1979

No. 1980 - 1989

No. 1990 - 1999

No. 2000 - 2009

No. 2010 - 2019

No. 2020 - 2029

No. 2030 - 2039

No. 2040 - 2049

No. 2050 - 2059

No. 2060 - 2069

No. 2070 - 2079

No. 2080 - 2089

No. 2090 - 2099

No. 2100 - 2109

No. 2110 - 2119

No. 2120 - 2129

No. 2130 - 2139

No. 2140 - 2149

No. 2150 - 2159

No. 2160 - 2169

No. 2170 - 2179

No. 2180 - 2189

No. 2190 - 2199

No. 2200 - 2209

No. 2210 - 2219

No. 2220 - 2229

No. 2230 - 2239

No. 2240 - 2249

No. 2250 - 2259

No. 2260 - 2269

No. 2270 - 2279

No. 2280 - 2289

No. 2290 - 2299

No. 2300 - 2309

No. 2310 - 2319

No. 2320 - 2329

No. 2330 - 2339

No. 2340 - 2349

No. 2350 - 2359

No. 2360 - 2369

No. 2370 - 2379

No. 2380 - 2389

No. 2390 - 2399

No. 2400 - 2409

No. 2410 - 2419

No. 2420 - 2429

No. 2430 - 2439

No. 2440 - 2449

No. 2450 - 2459

No. 2460 - 2469

No. 2470 - 2479

No. 2480 - 2489

No. 2490 - 2499

No. 2500 - 2509

No. 2510 - 2519

No. 2520 - 2529

No. 2530 - 2539

No. 2540 - 2549

No. 2550 - 2559

No. 2560 - 2569

No. 2570 - 2579

No. 2580 - 2589

No. 2590 - 2599

No. 2600 - 2609

No. 2610 - 2619

No. 2620 - 2629

No. 2630 - 2639

No. 2640 - 2649

No. 2650 - 2659

No. 2660 - 2669

No. 2670 - 2679

No. 2680 - 2689

No. 2690 - 2699

No. 2700 - 2709

No. 2710 - 2719

No. 2720 - 2729

No. 2730 - 2739

No. 2740 - 2749

No. 2750 - 2759

No. 2760 - 2769

No. 2770 - 2779

No. 2780 - 2789

No. 2790 - 2799

No. 2800 - 2809

No. 2810 - 2819

No. 2820 - 2829

No. 2830 - 2839

No. 2840 - 2849

No. 2850 - 2859

No. 2860 - 2869

No. 2870 - 2879

No. 2880 - 2889

No. 2890 - 2899

No. 2900 - 2909

No. 2910 - 2919

No. 2920 - 2929

No. 2930 - 2939

No. 2940 - 2949

No. 2950 - 2959

No. 2960 - 2969

No. 2970 - 2979

No. 2980 - 2989

No. 2990 - 2999

No. 3000 - 3009

No. 3010 - 3019

No. 3020 - 3029

No. 3030 - 3039

No. 3040 - 3049

No. 3050 - 3059

No. 3060 - 3069

No. 3070 - 3079

No. 3080 - 3089

No. 3090 - 3099

No. 3100 - 3109

No. 3110 - 3119

No. 3120 - 3129

No. 3130 - 3139

No. 3140 - 3149

No. 3150 - 3159

No. 3160 - 3169

No. 3170 - 3179

No. 3180 - 3189

No. 3190 - 3199

No. 3200 - 3209

No. 3210 - 3219

No. 3220 - 3229

No. 3230 - 3239

No. 3240 - 3249

No. 3250 - 3259

No. 3260 - 3269

No. 3270 - 3279

No. 3280 - 3289

No. 3290 - 3299

No. 3300 - 3309

No. 3310 - 3319

No. 3320 - 3329

No. 3330 - 3339

No. 3340 - 3349

No. 3350 - 3359

No. 3360 - 3369

No. 3370 - 3379

No. 3380 - 3389

No. 3390 - 3399

No. 3400 - 3409

No. 3410 - 3419

No. 3420 - 3429

No. 3430 - 3439

No. 3440 - 3449

No. 3450 - 3459

No. 3460 - 3469

No. 3470 - 3479

No. 3480 - 3489

No. 3490 - 3499

No. 3500 - 3509

No. 3510 - 3519

No. 3520 - 3529

No. 3530 - 3539

No. 3540 - 3549

No. 3550 - 3559

No. 3560 - 3569

No. 3570 - 3579

No. 3580 - 3589

No. 3590 - 3599

No. 3600 - 3609

No. 3610 - 3619

No. 3620 - 3629

No. 3630 - 3639

No. 3640 - 3649

No. 3650 - 3659

No. 3660 - 3669

No. 3670 - 3679

No. 3680 - 3689

No. 3690 - 3699

No. 3700 - 3709

No. 3710 - 3719

No. 3720 - 3729

No. 3730 - 3739

No. 3740 - 3749

No. 3750 - 3759

No. 3760 - 3769

No. 3770 - 3779

No. 3780 - 3789

No. 3790 - 3799

No. 3800 - 3809

No. 3810 - 3819

No. 3820 - 3829

No. 3830 - 3839

No. 3840 - 3849

No. 3850 - 3859

No. 3860 - 3869

No. 3870 - 3879

No. 3880 - 3889

No. 3890 - 3899

No. 3900 - 3909

No. 3910 - 3919

No. 3920 - 3929

No. 3930 - 3939

No. 3940 - 3949

No. 3950 - 3959

No. 3960 - 3969

No. 3970 - 3979

No. 3980 - 3989

No. 3990 - 3999

No. 4000 - 4009

No. 4010 - 4019

No. 4020 - 4029

No. 4030 - 4039

No. 4040 - 4049

No. 4050 - 4059

No. 4060 - 4069

No. 4070 - 4079

No. 4080 - 4089

No. 4090 - 4099

No. 4100 - 4109

No. 4110 - 4119

No. 4120 - 4129

No. 4130 - 4139

No. 4140 - 4149

No. 4150 - 4159

No. 4160 - 4169

No. 4170 - 4179

No. 4180 - 4189

No. 4190 - 4199

No. 4200 - 4209

No. 4210 - 4219

No. 4220 - 4229

No. 4230 - 4239

No. 4240 - 4249

No. 4250 - 4259

No. 4260 - 4269

No. 4270 - 4279

No. 4280 - 4289

No. 4290 - 4299

No. 4300 - 4309

No. 4310 - 4319

No. 4320 - 4329

No. 4330 - 4339

No. 4340 - 4349

No. 4350 - 4359

No. 4360 - 4369

No. 4370 - 4379

No. 4380 - 4389

No. 4390 - 4399

No. 4400 - 4409

No. 4410 - 4419

No. 4420 - 4429

No. 4430 - 4439

No. 4440 - 4449

No. 4450 - 4459

No. 4460 - 4469

No. 4470 - 4479

No. 4480 - 4489

No. 4490 - 4499

No. 4500 - 4509

No. 4510 - 4519

No. 4520 - 4529

No. 4530 - 4539

No. 4540 - 4549

No. 4550 - 4559

No. 4560 - 4569

No. 4570 - 4579

No. 4580 - 4589

No. 4590 - 4599

No. 4600 - 4609

No. 4610 - 4619

No. 4620 - 4629

No. 4630 - 4639

No. 4640 - 4649

No. 4650 - 4659

No. 4660 - 4669

No. 4670 - 4679

No. 4680 - 4689

No. 4690 - 4699

No. 4700 - 4709

No. 4710 - 4719

No. 4720 - 4729

No. 4730 - 4739

No. 4740 - 4749

No. 4750 - 4759

No. 4760 - 4769

No. 4770 - 4779

No. 4780 - 4789

No. 4790 - 4799

No. 4800 - 4809

No. 4810 - 4819

No. 4820 - 4829

No. 4830 - 4839

No. 4840 - 4849

No. 4850 - 4859

No. 4860 - 4869

No. 4870 - 4879

No. 4880 - 4889

No. 4890 - 4899

No. 4900 - 4909

No. 4910 - 4919

No. 4920 - 4929

No. 4930 - 4939

No. 4940 - 4949

No. 4950 - 4959

No. 4960 - 4969

No. 4970 - 4979

No. 4980 - 4989

No. 4990 - 4999

No. 5000 - 5009

No. 5010 - 5019

No. 5020 - 5029

No. 5030 - 5039

No. 5040 - 5049

No. 5050 - 5059

No. 5060 - 5069

No. 5070 - 5079

No. 5080 - 5089

No. 5090 - 5099

No. 5100 - 5109

No. 5110 - 5119

No. 5120 - 5129

No. 5130 - 5139

No. 5140 - 5149

No. 5150 - 5159

No. 5160 - 5169

No. 5170 - 5179

No. 5180 - 5189

No. 5190 - 5199

No. 5200 - 5209

No. 5210 - 5219

No. 5220 - 5229

No. 5230 - 5239

No. 5240 - 5249

No. 5250 - 5259

No. 5260 - 5269

No. 5270 - 5279

No. 5280 - 5289

No. 5290 - 5299

No. 5300 - 5309

No. 5310 - 5319

No. 5320 - 5329

No. 5330 - 5339

No. 5340 - 5349

No. 5350 - 5359

No. 5360 - 5369

No. 5370 - 5379

No. 5380 - 5389

No. 5390 - 5399

No. 5400 - 5409

No. 5410 - 5419

No. 5420 - 5429

No. 5430 - 5439

No. 5440 - 5449

No. 5450 - 5459

No. 5460 - 5469

No. 5470 - 5479

No. 5480 - 5489

No. 5490 - 5499

No. 5500 - 5509

No. 5510 - 5519

No. 5520 - 5529

No. 5530 - 5539

No. 5540 - 5549

No. 5550 - 5559

No. 5560 - 5569

No. 5570 - 5579

No. 5580 - 5589

No. 5590 - 5599

No. 5600 - 5609

No. 5610 - 5619

No. 5620 - 5629

No. 5630 - 5639

No. 5640 - 5649

No. 5650 - 5659

No. 5660 - 5669

No. 5670 - 5679

No. 5680 - 5689

No. 5690 - 5699

No. 5700 - 5709

No. 5710 - 5719

No. 5720 - 5729

No. 5730 - 5739

HISTORY



Michael Thonet (1796-1871) and his five children were the most successful manufacturers of furniture in the Industrial Age. Having

been invited to develop a patent in Austria by Chancellor Metternich, who had seen his products at the Exhibition held by the society of friends of arts in Koblenz, in 1842, Michael Thonet left Boppard in Germany, to settle in Vienna, where in 1853 he founded the company "Gebrüder Thonet" by involving his five sons. In the Hapsburg capital, Michael Thonet abandoned the more traditional technique of glued lamellar wood in favour of the industrial chemical - mechanical steam bent process. This innovation led him to begin producing wooden furniture, presenting a collection of elegant, yet practical designs that could be manufactured on a larger scale. He immediately supported this with a distribution and sales network that was capable of penetrating any market. It was during this time that products such as chair No. 1 designed for the famous Viennese Palais Schwarzenberg made their début, gaining fame as 'typically' Thonet, and from which many other models were then designed, up to and including the classic chair No. 14. The company's use of high technology and production techniques, together with widespread fame and a growing reputation, encouraged the most important Viennese architects to design new products. Otto Wagner commissioned the furnishing of the Post Sparkasse. Adolf Loos designed the chair for the Café Museum, in 1895 writing: "When I was in America, I realised that the Thonet chair was the most modern seating available". In 1911, the Gebrüder Thonet catalogue boasted 980 different models. By the end of the second world war, independent production plants had been set up in various different countries and

developed into separate businesses. In Austria, the home market of Gebrüder Thonet, the business was rebuilt by descendants of Michael Thonet, including his great-grandson Fritz Jakob Thonet as well as Fritz Jakob's children Evamarie Thonet and Richard Thonet. After the war, they had to start from scratch, with little more than their experience and passion for furniture. They recommenced their business in one of Gebrüder Thonet's former warehouses in Vienna. From 1948 on they rented a production site in Rohrau, Steiermark, before they finally built their own production site in Friedberg in 1962. In 1976 the Austrian business changed its name from Gebrüder Thonet to its current name Gebrüder Thonet Vienna. More recently, Gebrüder Thonet Vienna GmbH (GTV) has developed its work in a successful blend of the traditional and the modern, of continuity and renewal, with a new production program that begins by re-editing a series of Gebrüder Thonet classics.

At the same time, GTV stands for contemporary furnishing. Advanced production techniques are applied to innovative designs and uses of materials, to create highly sought-after, multipurpose furnishing items. Truly original, up-to-date solutions that integrate well with the more classic products of its catalogue, now reworked. Items such as chair No. 14, of which more than 50 million were made between 1850 and 1930, have gone down in history for their fine design and manufacturing quality, and yet still today excite and attract new generations. GTV always succeeds in finding the perfect combination of tradition and innovation, assisted by continuous research into new, clear-cut, versatile designs. GTV is open and looking to the future, without, however, leaving the values and experience of the past behind. This collection is a true reflection of the evolution of our times.

THE TECHNIQUE OF WOOD BENDING



The technique of wood bending is a very ancient technique existing in the craftsmanship of different civilizations, but remained in the corners for a long time due to a limited advantage in productivity.

the technique

The intuition of Michael Thonet took the moves from the observation that fresh wood is more flexible than dry wood : Starting from this consideration, Thonet and some of his contemporaries tested the bending of the wood sheets packets, dipped in boiling glue and then dried into rigid forms. This solution, however, did not guarantee the strength of the product, because of the precarious nature of the adhesive. To overcome this problem, Thonet tried to work only on the physical properties of the wood, by excluding all the glue from his procedures, in order to recover a considerable flexibility of the material – even after aging – by increasing the smoothness between the fibers by placing them in highly humid environment.

the patent

In 1842, Michael Thonet patented the process that made him famous throughout the world: the wood strips (beech, by far the favorite for its long, regular and knotless fiber) are turned, placed in an autoclave to absorb moisture, bent by force and fixed in metal forms, and finally dried; the finishing of the pieces was followed by the assembly of the “Vienna straw”, another element that became characteristic for the company. A real industrial process that went hand in hand with the progressive elimination of ornaments and joints, in favour of a rigorous line and careful attention to the simplification of the joining elements. Formal elegance, solidity and lightness have determined the success of the company that in a few years started production sites all over the world. A unique production process that has its roots in a history rich in suggestions and that is now renewed in the high quality of materials that Gebrüder Thonet Vienna chooses to make its products, characterized by valuable elements that unite them with high craftsmanship. The woods, selected for their strength and versatility, are combined with fabrics that enrich the range of colors proposed by the collection with precious nuances.

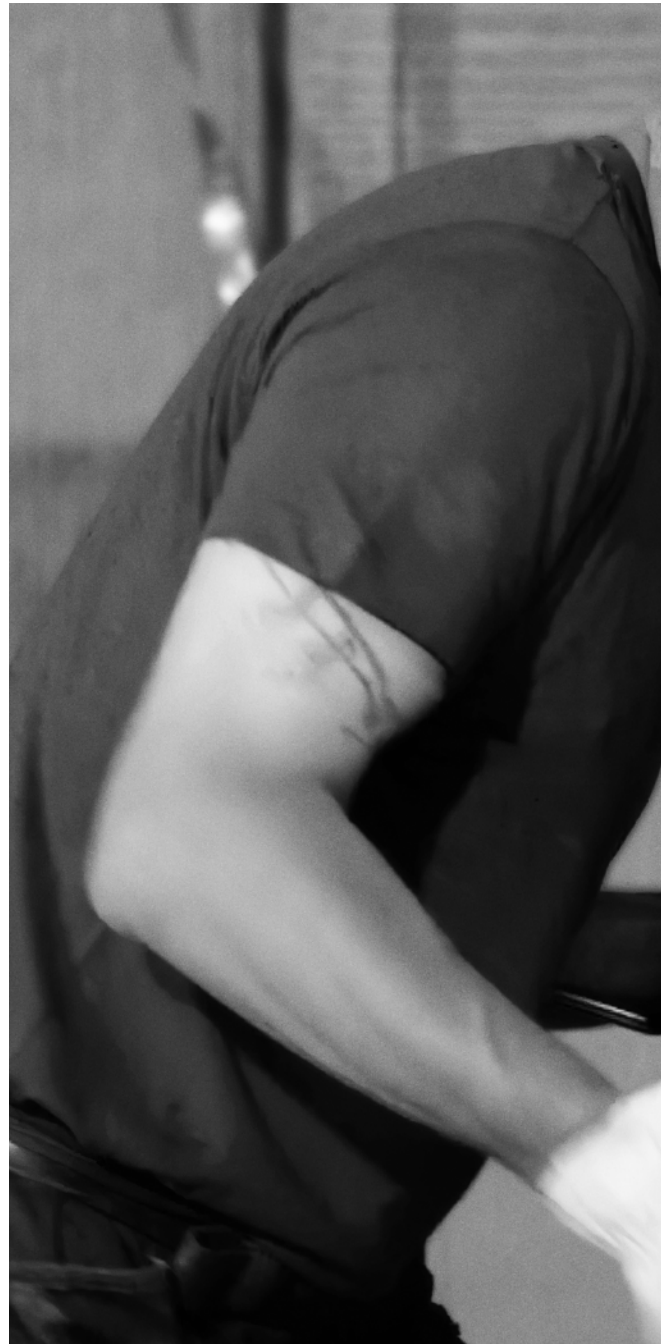



MON-ÎLE

Sergio Bicego

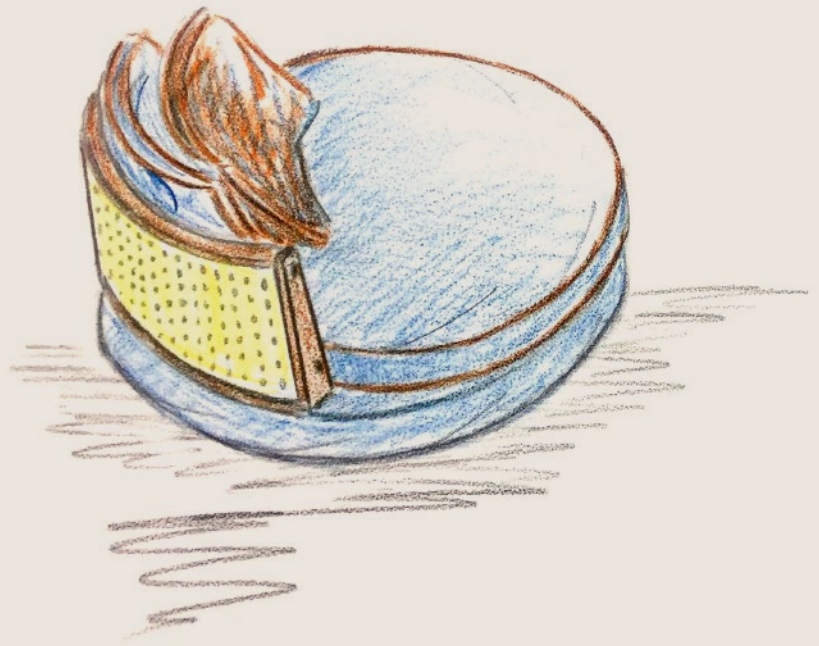

Born in the province of Vicenza in 1953, Sergio Bicego left his classical studies and began, almost by chance, his experience in the upholstered furniture sector. In 1991 he opened his own studio as an independent designer and since 1993 he has collaborated with various companies in the sector. His creations arise from the search for less formal solutions, equipped with systems that allow you to change with simple gestures, playing with shapes.

In 2024, the company's collection of upholstered furniture is enhanced with a new family designed by Sergio Bicego for residential environments: Mon-île offers a sofa and an armchair that modulate the domestic space by constructing phrases of varying lengths. The spacious and comfortable chairs create an archipelago that is intimate and communicative at the same time, in which the elements are added while imagining hosting conversations in infinite compositions.

The elegance of the fabrics, combined with simple and welcoming lines, expresses an idea of “quiet luxury” that whispers stories in which the main characters are the luxurious materials and attention to detail. The distinctive feature of the Vienna wickerwork is expressed in the backrest, which constitutes the only support element of the piece, and through the play with the fabrics, in a material and structural alternation, together with the curved wood, which we can also find in the coffee table that accompanies the soft island imagined by Sergio Bicego.

Versatile in terms of composition, and luxurious in the careful selection of materials, Mon-île combines, with discreet elegance, an intimate and cosy daily comfort that takes into account the spatial needs of contemporary homes.

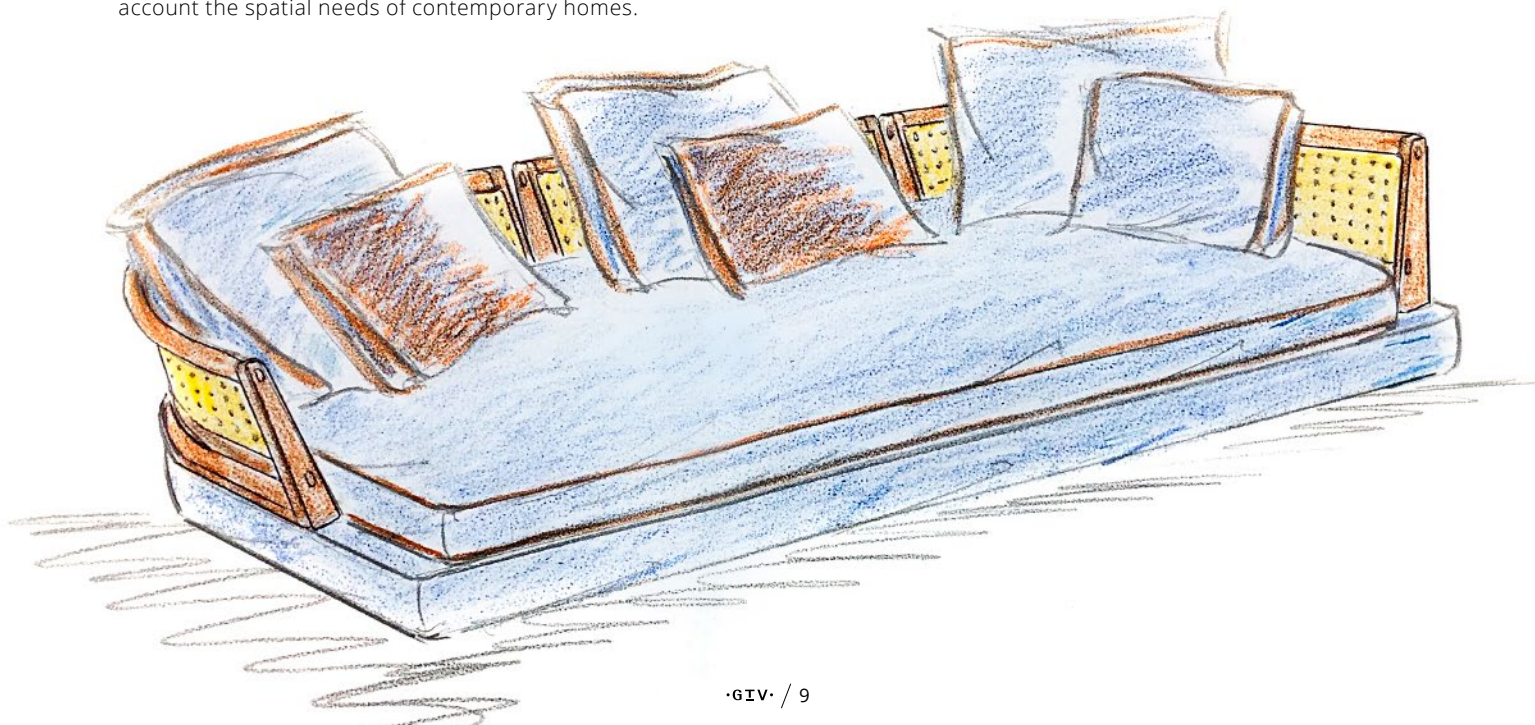
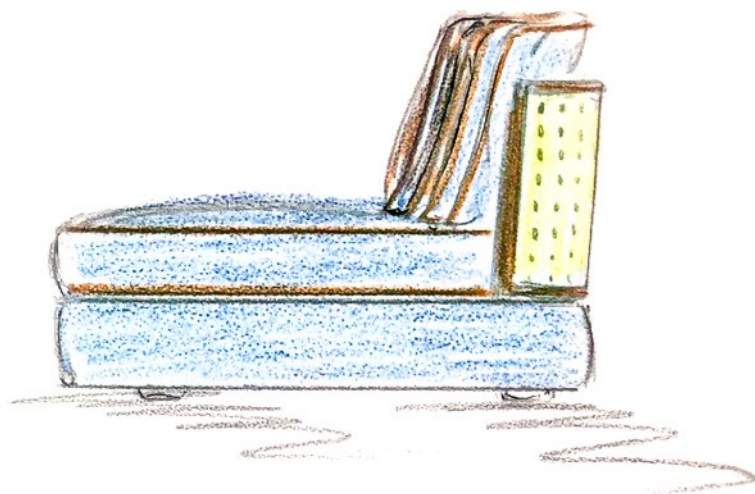

MON-ÎLE
DESIGN SERGIO BICEGO, 2024



























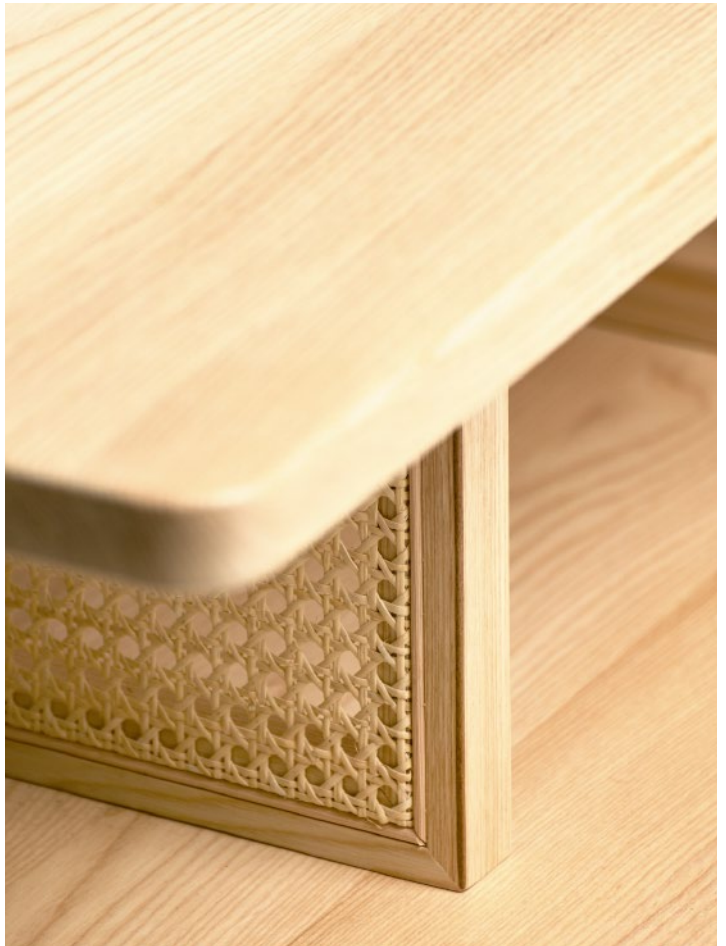









Upholstered furniture family consisting of a modular sofa and a round lounge armchair. The seat, made of differentiated-density polyurethane, is available in feather or polyester filling covered with fabrics, while the backrest is available upholstered or in woven cane with solid ash wood frame. The sofa is available in multiple combinations. Completing the collection are 2 ash wood coffee tables with woven cane inserts.

Familie von Polstermöbeln bestehend aus einem modularen Sofa und einem runden Loungesessel. Der Sitz aus differenzierten Polyurethanschaum ist in Feder oder Polyester erhältlich und in Kollektionstextilien bezogen, während die Rückenlehne gepolstert oder aus Wiener Geflecht mit einem Rahmen aus massiver Esche erhältlich ist. Das Sofa ist in mehreren Kombinationen erhältlich. Die Kollektion wird durch 2 Couchtische aus Eschenholz mit Einsätzen aus dem Wiener Geflecht vervollständigt.

Famiglia di imbottiti composta da un divano modulare e una poltrona lounge dalla forma rotonda. Il sedile in poliuretano a portanza differenziata è disponibile in piuma o poliesteri rivestito nei tessuti di collezione, lo schienale è disponibile imbottito o in paglia di Vienna con struttura in massello di frassino. Il divano è disponibile in molteplici combinazioni. Completano la collezione 2 tavolini in frassino con inserti in paglia di Vienna.

Famille de meubles rembourrés composée d'un canapé modulaire et d'un fauteuil lounge de forme ronde. Le siège en polyuréthane à portance différenciée est disponible en plumes ou en polyester revêtu de tissus de collection, tandis que le dossier est disponible rembourré ou en paille de Vienne avec une structure en frêne massif. Le canapé est disponible dans de multiples combinaisons. La collection est complétée par 2 tables basses en frêne avec des inserts en paille de Vienne.



SAMPLE COMPOSITION

LOUNGE CHAIR

COFFEE TABLES

Finishes:

SOLID WOOD



B07 ASH

STAINS

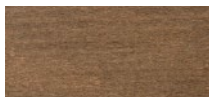

B08 BEECH-WOOD STAINED IN NOCE CANALETTO



DMM125TES
Dimensions mm.
height 420 | width 1250 | depth 950



DMM155TES
Dimensions mm.
height 420 | width 1550 | depth 950



DMM160TDX
Dimensions mm.
height 420 | width 1600 | depth 950



DMM160TSX
Dimensions mm.
height 420 | width 1600 | depth 950



DMM190TDX
Dimensions mm.
height 420 | width 1900 | depth 950



DMM190TSX
Dimensions mm.
height 420 | width 1900 | depth 950



DMM220TDX
Dimensions mm.
height 420 | width 2200 | depth 950



DMM220TSX
Dimensions mm.
height 420 | width 2200 | depth 950



DMM255TES
Dimensions mm.
height 420 | width 2550 | depth 950



DMM225TES
Dimensions mm.
height 420 | width 2250 | depth 950



PLMONITES
Dimensions mm.
height 420 | width 1000 | depth 1000



SCH120TES
Dimensions mm.
height 460 | width 1200 | depth 200



SCH090TES
Dimensions mm.
height 460 | width 900 | depth 200



SCHLDXTES
Dimensions mm.
height 460 | width 950 | depth 680



SCHLSXTES
Dimensions mm.
height 460 | width 950 | depth 680



SCHANGTES
Dimensions mm.
height 460 | width 680 | depth 680



SCH120PGL
Dimensions mm.
height 460 | width 1200 | depth 200



SCH090PGL
Dimensions mm.
height 460 | width 950 | depth 200



SCHLXPGL
Dimensions mm.
height 460 | width 950 | depth 680



SCHLXPGL
Dimensions mm.
height 460 | width 950 | depth 680



SCHANGPGL
Dimensions mm.
height 460 | width 680 | depth 680



TVMON2PGL
Dimensions mm.
height 475 | width 650 | depth 550



TVMON1PGL
Dimensions mm.
height 340 | width 950 | depth 550



CUD105TES
Dimensions mm.
height 580 | width 1050 | depth 200



CUD075TES
Dimensions mm.
height 580 | width 750 | depth 200



CUD062TES
Dimensions mm.
height 480 | width 620 | depth 120

YOU LucidiPevere



Paolo Lucidi (1974) Luca Pevere (1977). Both graduated and professionally trained in Milan, they started to develop their first projects together since 2003 and in 2006 founded their studio LucidiPevere. They are facing constant challenges using unusual technics and aesthetic means to develop new forms of products. Some of the brands LucidiPevere work with are De Padova, Zanotta, Gebrüder Thonet Vienna, Agape,

Ligne Roset, Hem, Foscarini, Kristalia, Living Divani, Normann Copenhagen, Emu, Arflex JP. Their products appeared in different museums and won major awards such as Designpreis Deutschland, Red Dot Design Award, Good Design Award, Compasso d'Oro Honourable mentions and many others. They took part in various exhibitions in Europe and in the U.S. and appeared in different publications.

The YOU stackable chair designed by LucidiPevere in 2024 is able to express the design minimalism that defines Gebrüder Thonet Vienna GmbH (GTV): an emblem of versatility, as it is able to multiply its uses thanks to its functional dynamism and refinement.

The elegant, curved solid arch gives the chair a unique aesthetic touch: it acts both as a graphic element, enhancing the side profile, and a functional one, because it ensures stability and practicality during the stacking phase, thanks to the protective rubber pads fixed at the ends.

The beech frame supports a shell that can be natural or coloured, with the possibility of padding in shades or in contrast: an opportunity to multiply the irreverent playfulness of this bistro chair with modular eclecticism into infinite stories.



YOU
DESIGN LUCIDIPEVERE, 2024









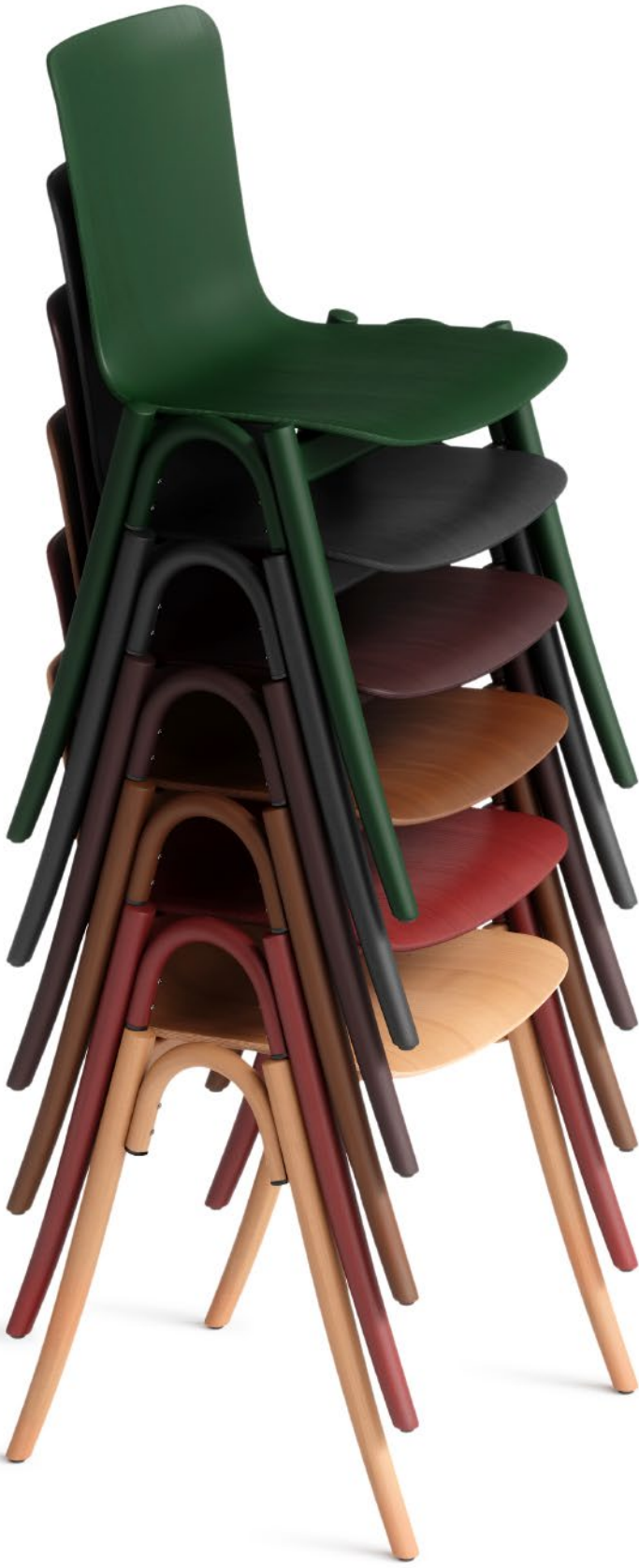

A **bistro chair** entirely made of wood, accessorizable with a **soft pad**.





Stackable chair with bent beech frame characterised by a solid arch that joins the legs and acts as a support to stacking. The beech plywood shell is available in wood or upholstered.

Stapelstuhl mit gebogenem Buchenholzgestell, gekennzeichnet durch einen massiven Bogen, der die Beine verbindet und als Stapelhilfe dient. Die Sitzschale aus Buchenschichtholz ist in Holz oder gepolstert erhältlich.

Sedia impilabile con struttura in faggio curvato caratterizzata da un arco in legno massello che unisce le gambe e funge da supporto all'impilabilità. La scocca in multistrato di faggio è disponibile in legno o imbottita.

Chaise empilable avec cadre en hêtre courbé caractérisée par une arche solide qui relie les pieds et sert de support à l'empilage. La coque en contreplaqué de hêtre est disponible en bois ou rembourrée.



SDYOUCLGN
Dimensions mm.
H 815 | W 560 | D 510 | SH 460

SDYOUCTES
Dimensions mm.
H 815 | W 560 | D 510 | SH 460

Stackable max. 10

Finishes:

SOLID WOOD / ESSENZE NATURALI

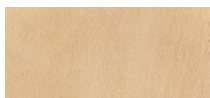

B01 BEECH

STAINS / TINTI



B03 DARK WALNUT



B04 WENGÈ



B08 BEECH-WOOD STAINED IN NOCE CANALETTO

COLOURED STAINS / TINTI COLORATI



GREEN/VERDE NCS S 5540 - B80G



RED/ROSSO NCS S 2070 - Y90R

AMPLE OUTDOOR COLLECTION

Nichetto Studio

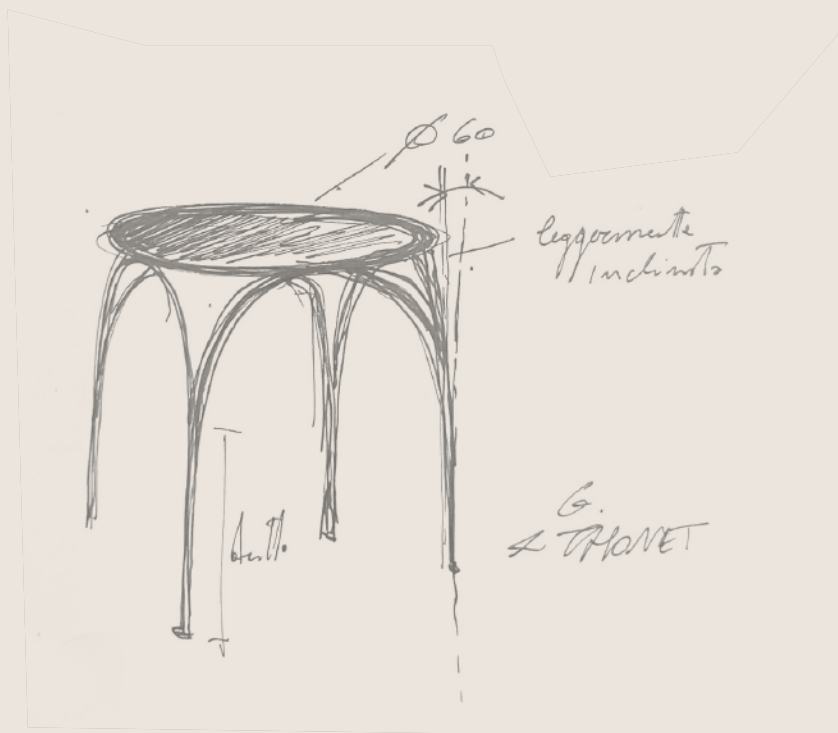

Luca Nichetto founded his eponymous multidisciplinary design practice in Venice, Italy in 2006, specialising in industrial design, product design and design consultancy. From the very beginning, Nichetto Studio worked with a number of different brands and organisations; these collaborations were to become a cornerstone of his work and his influence had soon expanded far beyond Venice and Italy's borders. Fellow Treviso-born designer Francesco Dompieri joined the studio as a partner in 2007, and four years later, Nichetto opened a second studio in Stockholm, Sweden, catering to an ever growing number of requests for collaboration from international companies. Soon, the studio's work was

broadening out from its initial focus on designed objects. Today, the studio works with a variety of brands and clients from around the world and its expertise is sought out across all design disciplines.

A deep passion for, and knowledge of, industrial and craft manufacturing processes runs through every aspect of the studio's work. Its projects abound in carefully selected cultural references and a keen attention to detail. The practice's unique position within both Scandinavian and Italian design culture has given Nichetto Studio worldwide acclaim that extends far beyond the confines of the design industry.

Nichetto Studio proudly announces the launch of an elegant extension of the Ample family: The Ample Outdoor Chair and the Ample Bistrot Table, designed as versatile outdoor counterparts to effortlessly harmonize indoor and outdoor settings.

Originally conceived for indoor use, the Ample Outdoor Chair now offers a versatile outdoor version, expanding its utility while maintaining the iconic design language of Gebrüder Thonet Vienna GmbH (GTV). Inspired by the esteemed brand's rich heritage and commitment to timeless craftsmanship, Nichetto Studio embarked on a journey to reimagine classic concepts with a contemporary twist.

Central to the design process was the exploration of Gebrüder Thonet Vienna's iconic pieces, seeking untapped avenues for innovation. Embracing the challenge of marrying tradition with novelty, Nichetto Studio introduced a ground-breaking approach by applying the steam bent process, traditionally used with wood, to metal. This innovative technique allowed the Studio to push boundaries and achieve unprecedented results.

The result is the birth of the Ample Outdoor Chair and the Ample Bistrot Table, distinguished by their sinuous silhouettes, generous proportions, and unmatched comfort. Whether gracing residential spaces or commercial settings, Ample embodies the essence of craftsmanship, tradition, and innovation in a singular product.

Luca Nichetto, founder of Nichetto Studio, remarked, "When Gebrüder Thonet Vienna approached us for a potential collaboration, it was a moment of great honor. With Ample, we aim to contribute to GTV's illustrious legacy by introducing new material while staying true to their centuries-old tradition."

With its timeless elegance and sculptural beauty, Ample transcends boundaries, effortlessly adapting to diverse environments and settings. It stands as a testament to the enduring partnership between Nichetto Studio and Gebrüder Thonet Vienna, embodying their shared commitment to design excellence.

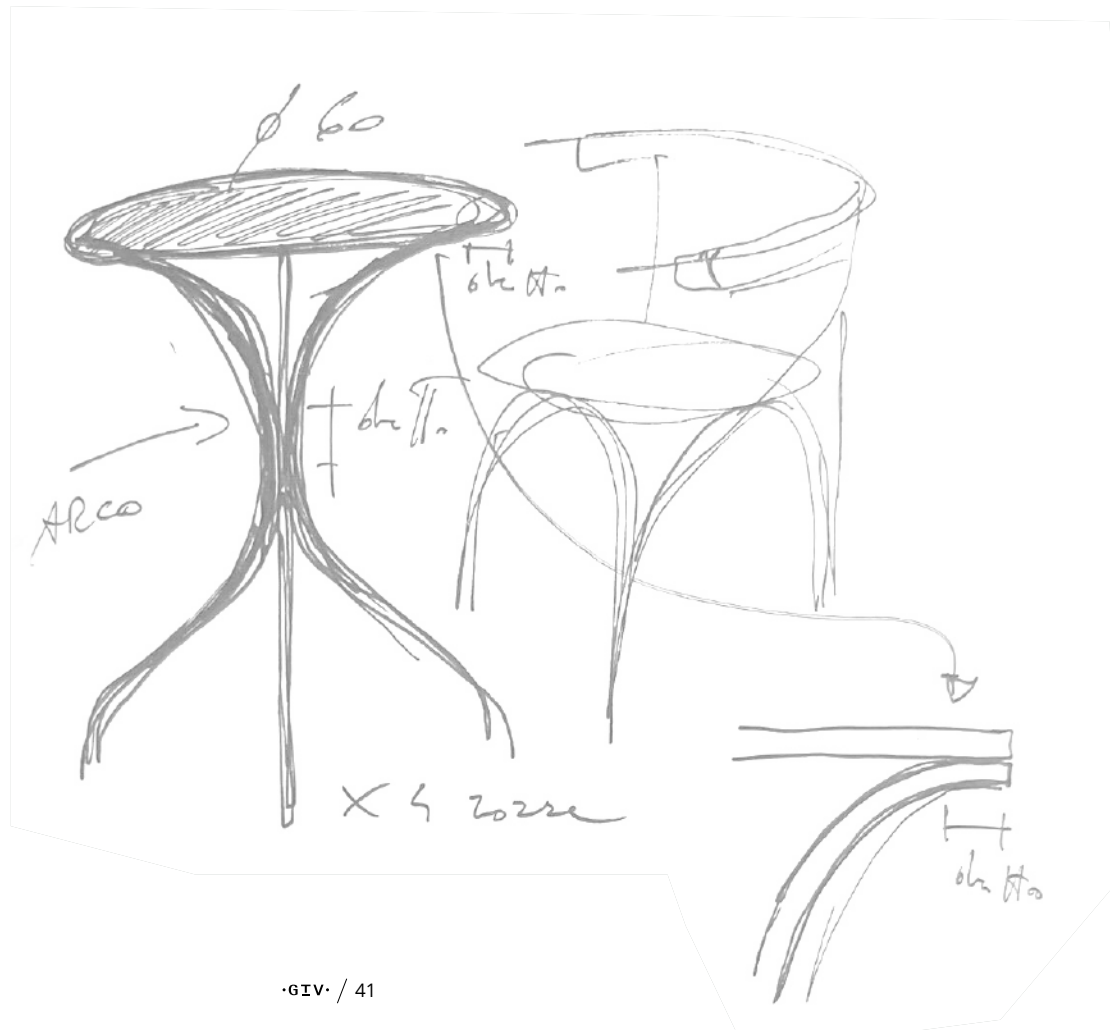

AMPLE OUTDOOR

DESIGN NICHETTO STUDIO, 2024









AMPLE OUTDOOR CHAIR

Outdoor chair made with an iron tubular frame and seat and backrest in Iroko wood. Also available in the indoor version.

Outdoor-Stuhl mit einem Gestell aus Eisenrohr und Sitz- und Rückenlehne aus Iroko-Holz. Auch in der Indoor-Version erhältlich.

Sedia outdoor realizzata con struttura in tubolare di ferro e seduta e schienale in legno Iroko. Disponibile anche nella versione indoor.

Chaise d'extérieur réalisée avec une structure en tube de fer et assise et dossier en bois d'Iroko. Disponible également en version intérieure.



SDAMPLGN
Dimensions mm.
H 750 | W 510 | D 500 | SH 450

Finishes:

STRUCTURE

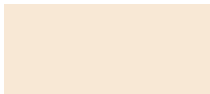

D01 - RAL 1013 PEARL WHITE

SEAT AND BACKREST



B09 - IROKO

STRUCTURE



D31 - RAL 7022 UMBRA GREY

SEAT AND BACKREST



B09 - IROKO

STRUCTURE



D14 - RAL 3005 WINE RED

SEAT AND BACKREST



B09 - IROKO

AMPLE OUTDOOR BISTRO TABLES

Outdoor bistro tables with a metal tubular frame and Iroko wood top. Available in two different versions. The 4-legged version is stackable. Also available in the indoor version.

Bistro-Tische für den Außenbereich mit einem Gestell aus Metallrohr und einer Tischplatte aus Iroko-Holz. In zwei verschiedenen Ausführungen erhältlich. Die 4-beinige Version ist stapelbar. Auch in der Indoor-Version erhältlich.

Tavoli da bistrot da esterno con struttura in tubolare metallico e piano in legno Iroko. Disponibile in due diverse varianti. La variante a 4 gambe è impilabile. Disponibile anche nella versione indoor.

Tables de bistrot d'extérieur avec une structure en tube métallique et un plateau en bois d'Iroko. Disponible en deux versions différentes. La version à 4 pieds est empilable. Disponible également en version intérieure.



TVAMPLLGN
Dimensions mm.
H 760 | W 600 | D 600

TVAMPLLG2
Dimensions mm.
H 760 | W 800 | D 800

Finishes:

STRUCTURE

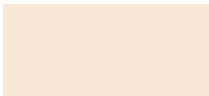

D01 - RAL 1013 PEARL WHITE

TOP



B09 - IROKO

STRUCTURE



D31 - RAL 7022 UMBRA GREY

TOP



B09 - IROKO

STRUCTURE



D14 - RAL 3005 WINE RED

TOP



B09 - IROKO



INDEX OF FABRICS SHOWN IN THE PICTURES

Arcadia

pag. 58,69 Kvadrat Vidar 4 col. 0743

Loie

pag. 59 Kvadrat Fuse 0121

Mon-île

pag.10, 11, 12, 13 Romeo 1855 col.18

Piping Nuvola col. 135

Decorative Pillows:

Kvadrat Moss 0003

Kvadrat Sonar 3 col. 0934

pag. 14, 15 Rico 989 col. 000

Decorative Pillows:

Nabucco col. 4037

Solemio 1807 col. 07

pag. 16, 17 Laser J col. 1049

Piping Coccio col. 96

Decorative Pillows:

Kvadrat Harald 3 col. 0443

pag. 18, 19, 20, 25 Boemian 624 col. 60

Decorative Pillows:

Kvadrat Vidar 4 col. 0743

Kvadrat Vidar 4 col. 0554

Mon-île lounge chair

pag.16, 17 Rustico col. 9715

pag. 26, 27 Boemian 624 col. 10

Decorative Pillow pag. 27

Kvadrat Vidar 4 col. 956

You

pag. 32, 33 Kvadrat Raas 462

pag. 37 Kvadrat Reflect 984

TECHNICAL SHEET

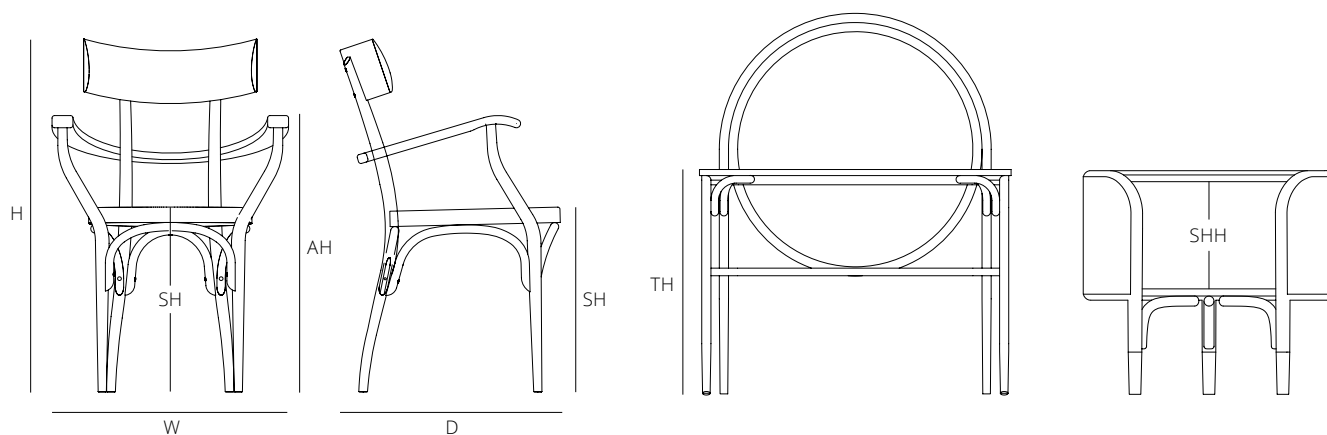

Key to Dimensions:

H

Height
Höhe
Altezza
Hauteur

W

Width
Breite
Larghezza
Largeur

D

Depth
Tiefe
Profondità
Profondeur

SH

Seat Height
Sitzhöhe
Altezza Seduta
Hauteur Assise

AH

Arm Height
Höhe Armlehne
Altezza Bracciolo
Hauteur Accoudoir

TH

Top Height
Höhe Platte
Altezza Top
Hauteur Top

SHH

Shelves Height
Höhe der Regale
Altezza Scaffali
Hauteur des étagères

Art Direction:

Gebrüder Thonet Vienna GmbH

Graphic Project:

Graphicstudio | Gianfranco Martorella

Styling:

Gaia Marchesini e Giordano Sarno

Photo:

Margherita Bonetti

Serena Eller

Cosé Manuel Rossi e Germán Bourgeat

Giovanni Della Ceca

Props:

Alessi

Amini

Astep

Bitossi Ceramiche

cc-tapis

Oluce

raawii

Vero International

Vitra

The Manufacturer reserves the right to modify products and accessories at any time without prior notice.

Die Firma behält sich vor, Produkte und Zubehör unabhängig vom Zeitpunkt und ohne jede Voranmeldung zu ändern.

L'azienda si riserva il diritto in qualunque momento di apportare senza preavviso modifiche a prodotti e accessori.

L'entreprise se réserve de modifier les articles et les accessoires en chaque moment et sans préavis.

L'azienda si dichiara disponibile a riconoscere eventuali diritti per il materiale iconografico di cui non sia stato possibile individuare la fonte.

The manufacturer declares to be available to recognize possible rights for iconographic material, whose origin was not possible to be traced back.

Gebrüder Thonet Vienna GmbH

Prinz Eugen Straße 42 - 1040 Wien, (AT)
www.gebruederthonetvienna.com

Offices of the trademarks' licensee
Production Furniture International S.p.A.
Via Foggia, 23/H - 10152 Torino (TO) Italy
Phone: 0039 011 0133330
info@gebruederthonetvienna.com

Print: AGT s.r.l. (TO) 07/2024

When printing on paper, the shades of the colours of various materials cannot be faithfully reproduced. Therefore it must only be considered indicative and cannot constitute a reason for dispute or for the return of the product.

Bei Papierdruck können die Farbtöne der verschiedenen Materialien nicht originalgetreu wiedergegeben werden. Bei den Abbildungen sind daher Abweichungen möglich, die kein Recht auf Beanstandungen oder Rückgabe des Produkts begründen.

Nella stampa su carta, la tonalità dei colori dei vari materiali non può essere riprodotta fedelmente. Pertanto deve considerarsi indicativa e non potrà costituire motivo di contestazione o di resa del prodotto.

Lors de l'impression sur papier, la tonalité des couleurs des différents matériaux ne peut pas être parfaitement reproduite. Les couleurs ne sont donc qu'indicatives et ne pourront pas constituer un motif de contestation ou de retour du produit.

Printed on Fedrigoni Symbol Matt Plus Premium White.



